



भारतीय प्रौद्योगिकी संस्थान तिरुपति

Indian Institute of Technology Tirupati
Yerpedu – Venkatagiri Road, Yerpedu Post,
Tirupati District, A.P - 517619

Telephone: 0877- 2503572, Email: purchase@iittp.ac.in

Tender No. IITT/EU/2023-24/02

01st May 2023.

**NOTICE INVITING TENDER FOR SUPPLY, INSTALLATION, TESTING, AND
COMMISSIONING OF LAB FURNITURE**

(E-PROCUREMENT MODE ONLY)

Indian Institute of Technology Tirupati (IIT Tirupati) invites online bids (e-tender) in Two bid systems from eligible **Class-I & Class-II Local suppliers** in line with Government Public Procurement order No.P-45021/2/2017-BE-II dated: 04.06.2020 for the following:

Set .no	Item Description	Quantity (approx.)	Tender Fee (Inclusive of all taxes in Rs.)
1. Work Table:			
A	Item no. 1: Granite top work benches (Standard size) (with Trunking) (with 2 LAN ports)	134 Nos	2500/-
B	Item no. 2: Granite top work benches (Standard size) (with Trunking) (without LAN ports)	74 Nos	
C	Item no. 3: Granite nbt top work benches (high rise) (with Trunking) (without LAN ports)	171 Nos	
D	Item no. 4: Granite top work benches (custom size) (with Trunking) (1 LAN port)	57 Nos	
E	Item no. 5: Granite top work benches (custom size) (without Trunking)	34 Nos	
F	Item no. 6: Table with Granite Top (Special Table 1) (without trunking)	3 Nos	
G	Item no. 7: Table with Granite Top (Special Table 2) (without trunking)	7 Nos	
H	Item no. 8: Table with Granite Top (Special Table 3) (without trunking)	6 Nos	
I	Item no. 9: Table with Granite Top (Special Table 4) (without trunking)	4 Nos	
J	Item no. 10: Granite Table with sink	13 Nos	
2.	Item no. 11: Under Bench Trolley	284 Nos	
3.	Item no. 12: Double door Wall mounted storage cabinets	201 Nos	
4. Student Chairs:			

A	Item no. 13: Student Chairs (Type 1-UG Labs)	138 Nos	
B	Item no. 14: Student Chairs (Type 2-Research Labs)	583 Nos	

The Item No.1 to 10 combined as set No.1, Item No. 11 as set no.2, Item No. 12 as set no.3, Item No. 13 & 14 combined as set No. 4 and the evaluation will be on the basis of set wise. Based on the eligibility criteria, Bidder (s) can quote for one or more sets (s). L1 will be decided on Set-wise i.e.

*****Set No- 1 [Item No.1 to 10]**

Set No- 2 [Item No.11]

Set No- 3 [Item No.12]

Set No- 4 [Item No. 13&14]

Note: * The work order will be release set wise only**

The Tender Document can be downloaded from Central Public Procurement (CPP) Portal <http://eprocure.gov.in/eprocure/app> and [www. iittp.ac.in/tenders/](http://www.iittp.ac.in/tenders/) bid is to be submitted online only through the same portal up to the last date and time of submission of tender.

Critical Dates of Tender:

1	Date and time of Online Publication/Download of Tenders	01.05.2023	18.00 hrs
2	Clarifications start date	01.05.2023	18.00 hrs
3	Clarifications end date	15.05.2023	15.00 hrs
4	Uploading of corrigendum after the receipt of clarifications (If any)	16.05.2023	15.00 hrs
5	Bid submission start date & time	02.05.2023	10.00 hrs
6	Bid submission close date & time	24.05.2023	15.00 hrs
7	Closing date & time for submission of EMD/Tender fee	24.05.2023	15.00 hrs
8	Opening of Technical bids	25.05.2023	15.00 hrs

All Technical and Specification-related queries may be forwarded to Email ID: eutenders@iittp.ac.in before the clarifications end date as per the format provided in the Annexure-X.

1. About IIT TIRUPATI:

Indian Institute of Technology Tirupati (IIT Tirupati) is an Autonomous Institute under the Ministry of Education, Govt. of India.

2. Technical Specifications: Schedule of requirement

Item No-1 : GRANITE TOP WORK BENCH (STANDARD SIZE) WITH TRUNKING AND 2 LAN PORTS

1. Overall Dimensions:

Length	– 1524 mm ± 10 mm
Width	– 914 mm ± 10 mm
Height	– 750 mm ± 10 mm

2. C-Frame System

- All C-Frames assemblies should be manufactured from standard hollow metal sections; conforming to I.S. Code 7138:1993 (Indian Standard specification for steel tubes for furniture).
- All sheet metal components should be of CRCA conforming to IS Code 513:2016.
- C-frame should be constructed from a rectangular pipe with a cross section of 60 mm x 30 mm and should be 2 mm thick and should be without a vertical front leg to give a clean look.
- This shall provide more knee space or leg space and would facilitate uninterrupted lateral movement of the under-bench units within the bench run.
- The C-frame legs should be supplied with adjustable PVC nylon bush with high impact and vibration resistance (tolerance from -5 mm to +20 mm) to correct the unevenness of flooring.
- The structure should have a removable back panel to provide access for maintenance throughout the length of the table. The C-frame shall also have skirting at back bottom side.
- All framework should be pre-treated with superior pure epoxy powder coated finish.
- The C-Frames should be for Mobile Storage Cabinets that can be moved out of the workbench for better flexibility in design.
- All steel components need to be pre-treated with an acid wash, anticorrosive treatment prior to powder coating.
- The entire framework should be done with pure 70-80 microns epoxy powder coating.
- Scratch-resistant Powder Coat of required colour for all metal approved by IIT Tirupati shall be provided.
- All the welding should be done using the electro-welding process only.
- The standard of the table should be as per BIFMA X5.5-2021 (National Standard for Office and Institutional Furnishings - Desk and Table Products).

3. Horizontal Members

- CRCA Rectangular pipe of cross-section of 60 x 30 mm and 2 mm thickness shall be used with 70-80 microns pure epoxy powder coating.
- Horizontal members shall be connected using C-clamps/U-clamps with two adjacent C-Frames at a distance of 1500 mm together and that shall form the skeletal structure of the work bench on which the worktop can be placed

4. Removable Back Panels

- Removable back panels cover the service lines that run behind them.
- These should be easily removable (unclipped) and the service line be accessed for maintenance. This allows the equipment on the workbench to remain undisturbed.
- They should be made of CRCA sheet 1.2 mm of thickness and provided with 70-80 microns pure epoxy powder coating.

5. Side Cover and Filler Panels

- All side cover and filler panels should be made from CRCA sheet of 1.2 mm thickness with 70 – 80 microns pure epoxy powder coating.

6. Electrical Trunking

- The trunking for housing electrical switches and sockets along with 2 LAN Ports shall be made from 1.2 mm thick CRCA sheet with 70 – 80 microns pure epoxy powder coating.
- It should be available as single sided configurations (as per schedule of requirement) along with screwed caps.
- The front surface that houses the electrical points should have a slope.
- Each table should have 4 nos. of two in one 6/16 amp plug points with MCB. (2 plug pins in a single socket).

7. Worktop

- Jet Black Granite worktop should be of 18 ± 2 mm thick.
- The front edge of the granite must be chamfered properly at an angle of 28 degrees and should be properly smoothed.
- The bottom of the worktop should be polished and there should be a V-groove throughout the length of the exposed edges to protect the cabinets from coming in contact with the spillages.
- The overhang for the worktop is 25 mm at the front side and 30 mm at the sides.
- The backing material used is a neoprene mat of 6 mm thickness.
- All front corners shall be smoothly curved; and sharp corners should be avoid.
- Tabletop and other components should have a colour approved by IIT Tirupati.

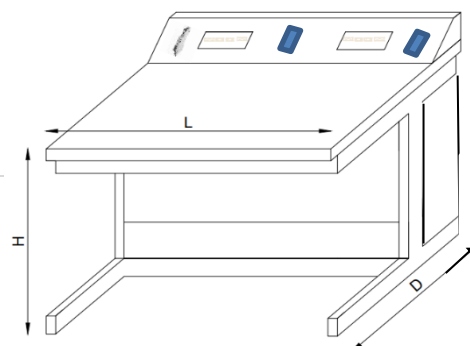
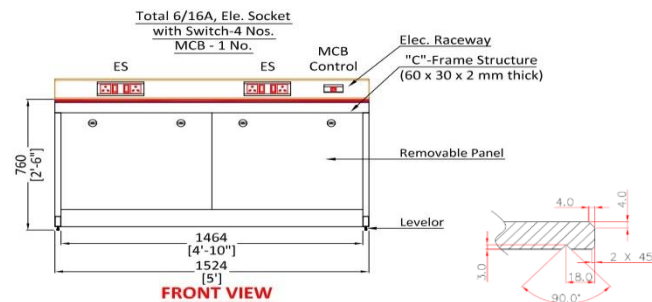
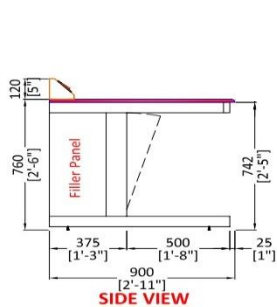
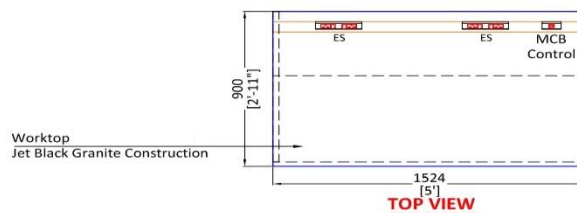

Fig (i) C-Frame Table with Electrical Trunking

Item No-2 : GRANITE TOP WORK BENCH (STANDARD SIZE) WITH TRUNKING AND WITHOUT LAN PORTS

1. Overall Dimensions:

Length	– 1524 mm ± 10 mm
Width	– 914 mm ± 10 mm
Height	– 750 mm ± 10 mm

2. C-Frame System

- All C-Frames assemblies should be manufactured from standard hollow metal sections; confirming to I.S. Code 7138:1993 (Indian Standard specification for steel tubes for furniture).
- All sheet metal components should be of CRCA confirming to IS Code 513:2016.
- C-frame should be constructed from a rectangular pipe with a cross section of 60 mm x 30 mm and should be 2 mm thick and should be without a vertical front leg to give a clean look.
- This shall provide more knee space or leg space and would facilitate uninterrupted lateral movement of the under-bench units within the bench run.
- The C-frame legs should be supplied with adjustable PVC nylon bush with high impact and vibration resistance (tolerance from -5 mm to +20 mm) to correct the unevenness of flooring.
- The structure should have a removable back panel to provide access for maintenance throughout the length of the table. The C-frame shall also have skirting at back bottom side.
- All framework should be pre-treated with superior pure epoxy powder coated finish.
- The C-Frames should be for Mobile Storage Cabinets that can be moved out of the workbench for better flexibility in design.
- All steel components need to be pre-treated with an acid wash, anticorrosive treatment prior to powder coating.
- The entire framework should be done with pure 70 – 80 microns epoxy powder coating.
- Scratch-resistant Powder Coat of required colour for all metal approved by IIT Tirupati shall be provided.
- All the welding should be done using the electro-welding process only.

- The standard of the table should be as per BIFMA X5.5-2021 (National Standard for Office and Institutional Furnishings - Desk and Table Products).

3. Horizontal Members

- CRCA Rectangular pipe of cross-section of 60 x 30 mm and 2 mm thickness shall be used with 70-80 microns pure epoxy powder coating.
- Horizontal members shall be connected using C-clamps/U-clamps with two adjacent C-Frames at a distance of 1500 mm together and that shall form the skeletal structure of the work bench on which the worktop can be placed.

4. Removable Back Panels

- Removable back panels cover the service lines that run behind them.
- These should be easily removable (unclipped) and the service line be accessed for maintenance. This allows the equipment on the workbench to remain undisturbed.
- They should be made of CRCA sheet 1.2 mm of thickness and provided with 70-80 microns pure epoxy powder coating.

5. Side Cover and Filler Panels

- All side cover and filler panels should be made from CRCA sheet of 1.2 mm thickness with 70 – 80 microns pure epoxy powder coating.

6. Electrical Trunking

- The trunking for housing electrical switches and sockets shall be made from 1.2 mm thick CRCA sheet with 70 – 80 microns pure epoxy powder coating.
- It should be available as single sided configurations (as per schedule of requirement) along with screwed caps.
- The front surface that houses the electrical points should have a slope.
- Each table should have 4 nos. of two in one 6/16 amp plug points with MCB. (2 plug pins in a single socket).

7. Worktop

- Jet Black Granite worktop should be of 18 ± 2 mm thick.
- The front edge of the granite must be chamfered properly at an angle of 28 degrees and should be properly smoothed.
- The bottom of the worktop should be polished and there should be a V-groove throughout the length of the exposed edges to protect the cabinets from coming in contact with the spillages.
- The overhang for the worktop is 25 mm at the front side and 30 mm at the sides.
- The backing material used is a neoprene mat of 6 mm thickness.
- All front corners shall be smoothly curved; and sharp corners should be avoided.
- Tabletop and other components should have a colour approved by IIT Tirupati.

Item No-3 : GRANITE TOP WORK BENCH (HIGH RISE) WITH TRUNKING AND WITHOUT LAN PORTS

1. Overall Dimensions:

Length	– 1524 mm ± 10 mm
Width	– 914 mm ± 10 mm
Height	– 914 mm ± 10 mm

2. C-Frame System

- All C-Frames assemblies should be manufactured from standard hollow metal sections; confirming to I.S. Code 7138:1993 (Indian Standard specification for steel tubes for furniture).
- All sheet metal components should be of CRCA confirming to IS Code 513:2016.
- C-frame should be constructed from a rectangular pipe with a cross section of 60 mm x 30 mm and should be 2 mm thick and should be without a vertical front leg to give a clean look.
- This shall provide more knee space or leg space and would facilitate uninterrupted lateral movement of the under-bench units within the bench run.
- The C-frame legs should be supplied with adjustable PVC nylon bush with high impact and vibration resistance (tolerance from -5 mm to +20 mm) to correct the unevenness of flooring.
- The structure should have a removable back panel to provide access for maintenance throughout the length of the table. The C-frame shall also have skirting at back bottom side.
- All framework should be pre-treated with superior pure epoxy powder coated finish.
- The C-Frames should be for Mobile Storage Cabinets that can be moved out of the workbench for better flexibility in design.
- All steel components need to be pre-treated with an acid wash, anticorrosive treatment prior to powder coating.
- The entire framework should be done with pure 70-80 microns epoxy powder coating.
- Scratch-resistant Powder Coat of required colour for all metal approved by IIT Tirupati shall be provided.
- All the welding should be done using the electro-welding process only.
- The standard of the table should be as per BIFMA X5.5-2021 (National Standard for Office and Institutional Furnishings - Desk and Table Products).

3. Horizontal Members

- CRCA Rectangular pipe of cross-section of 60 x 30 mm and 2 mm thickness shall be used with 70-80 microns pure epoxy powder coating.
- Horizontal members shall be connected using C-clamps/U-clamps with two adjacent C-Frames at a distance of 1500 mm together and that shall form the skeletal structure of the work bench on which the worktop can be placed.

4. Removable Back Panels

- Removable back panels cover the service lines that run behind them.

- These should be easily removable (unclipped) and the service line be accessed for maintenance. This allows the equipment on the workbench to remain undisturbed.
- They should be made of CRCA sheet 1.2 mm of thickness and provided with 70-80 microns pure epoxy powder coating.

5. Side Cover and Filler Panels

- All side cover and filler panels should be made from CRCA sheet of 1.2 mm thickness with 70 – 80 microns pure epoxy powder coating.

6. Electrical Trunking

- The trunking for housing electrical switches and sockets shall be made from 1.2 mm thick CRCA sheet with 70 – 80 microns pure epoxy powder coating.
- It should be available as single sided configurations (as per schedule of requirement) along with screwed caps.
- The front surface that houses the electrical points should have a slope.
- Each table should have 4 nos. of two in one 6/16 amp plug points with MCB. (2 plug pins in a single socket).

7. Worktop

- Jet Black Granite worktop should be of 18 ± 2 mm thick.
- The front edge of the granite must be chamfered properly at an angle of 28 degrees and should be properly smoothed.
- The bottom of the worktop should be polished and there should be a V-groove throughout the length of the exposed edges to protect the cabinets from coming in contact with the spillages.
- The overhang for the worktop is 25 mm at the front side and 30 mm at the sides.
- The backing material used is a neoprene mat of 6 mm thickness.
- All front corners shall be smoothly curved; and sharp corners should be avoided.
- Tabletop and other components should have a colour approved by IIT Tirupati.

Item No-4 : GRANITE TOP WORK BENCH (CUSTOM SIZE) WITH TRUNKING AND 1 LAN PORT

1. Overall Dimensions:

Length	– 914 mm \pm 10 mm
Width	– 914 mm \pm 10 mm
Height	– 750 mm \pm 10 mm

2. C-Frame System

- All C-Frames assemblies should be manufactured from standard hollow metal sections; conforming to I.S. Code 7138:1993 (Indian Standard specification for steel tubes for furniture).

- All sheet metal components should be of CRCA confirming to IS Code 513:2016.
- C-frame should be constructed from a rectangular pipe with a cross section of 60 mm x 30 mm and should be 2 mm thick and should be without a vertical front leg to give a clean look.
- This shall provide more knee space or leg space and would facilitate uninterrupted lateral movement of the under-bench units within the bench run.
- The C-frame legs should be supplied with adjustable PVC nylon bush with high impact and vibration resistance (tolerance from -5 mm to +20 mm) to correct the unevenness of flooring.
- The structure should have a removable back panel to provide access for maintenance throughout the length of the table. The C-frame shall also have skirting at back bottom side.
- All framework should be pre-treated with superior pure epoxy powder coated finish.
- The C-Frames should be for Mobile Storage Cabinets that can be moved out of the workbench for better flexibility in design.
- All steel components need to be pre-treated with an acid wash, anticorrosive treatment prior to powder coating.
- The entire framework should be done with pure 70-80 microns epoxy powder coating.
- Scratch-resistant Powder Coat of required colour for all metal approved by IIT Tirupati shall be provided.
- All the welding should be done using the electro-welding process only.
- The standard of the table should be as per BIFMA X5.5-2021 (National Standard for Office and Institutional Furnishings - Desk and Table Products).

3. Horizontal Members

- CRCA Rectangular pipe of cross-section of 60 x 30 mm and 2 mm thickness shall be used with 70-80 microns pure epoxy powder coating.
- Horizontal members shall be connected using C-clamps/U-clamps with two adjacent C-Frames at a distance of 900 mm together and that shall form the skeletal structure of the work bench on which the worktop can be placed.

4. Removable Back Panels

- Removable back panels cover the service lines that run behind them.
- These should be easily removable (unclipped) and the service line be accessed for maintenance. This allows the equipment on the workbench to remain undisturbed.
- They should be made of CRCA sheet 1.2 mm of thickness and provided with 70-80 microns pure epoxy powder coating.

5. Side Cover and Filler Panels

- All side cover and filler panels should be made from CRCA sheet of 1.2 mm thickness with 70 – 80 microns pure epoxy powder coating.

6. Electrical Trunking

- The trunking for housing electrical switches and sockets along with 1 LAN Port shall be made from 1.2 mm thick CRCA sheet with 70 – 80 microns pure epoxy powder coating.
- It should be available as single sided configurations (as per schedule of requirement) along with screwed caps.
- The front surface that houses the electrical points should have a slope.
- Each table should have 4 nos. of two in one 6/16 amp plug points with MCB. (2 plug pins in a single socket).

7. Worktop

- Jet Black Granite worktop should be of 18 ± 2 mm thick.
- The front edge of the granite must be chamfered properly at an angle of 28 degrees and should be properly smoothed.
- The bottom of the worktop should be polished and there should be a V-groove throughout the length of the exposed edges to protect the cabinets from coming in contact with the spillages.
- The overhang for the worktop is 25 mm at the front side and 30 mm at the sides.
- The backing material used is a neoprene mat of 6 mm thickness.
- All front corners shall be smoothly curved; and sharp corners should be avoided.
- Tabletop and other components should have a colour approved by IIT Tirupati.

Item No-5: GRANITE TOP WORK BENCH (CUSTOM SIZE) WITHOUT TRUNKING AND WITHOUT LAN PORT

1. Overall Dimensions:

Length	– 914 mm \pm 10 mm
Width	– 914 mm \pm 10 mm
Height	– 750 mm \pm 10 mm

2. C-Frame System

- All C-Frames assemblies should be manufactured from standard hollow metal sections; confirming to I.S. Code 7138:1993 (Indian Standard specification for steel tubes for furniture).
- All sheet metal components should be of CRCA confirming to IS Code 513:2016.
- C-frame should be constructed from a rectangular pipe with a cross section of 60 mm x 30 mm and should be 2 mm thick and should be without a vertical front leg to give a clean look.
- This shall provide more knee space or leg space and would facilitate uninterrupted lateral movement of the under-bench units within the bench run.
- The C-frame legs should be supplied with adjustable PVC nylon bush with high impact and vibration resistance (tolerance from -5 mm to +20 mm) to correct the unevenness of flooring.

- The structure should have a removable back panel to provide access for maintenance throughout the length of the table. The C-frame shall also have skirting at back bottom side.
- All framework should be pre-treated with superior pure epoxy powder coated finish.
- The C-Frames should be for Mobile Storage Cabinets that can be moved out of the workbench for better flexibility in design.
- All steel components need to be pre-treated with an acid wash, anticorrosive treatment prior to powder coating.
- The entire framework should be done with pure 70-80 microns epoxy powder coating.
- Scratch-resistant Powder Coat of required colour for all metal approved by IIT Tirupati shall be provided.
- All the welding should be done using the electro-welding process only.
- The standard of the table should be as per BIFMA X5.5-2021 (National Standard for Office and Institutional Furnishings - Desk and Table Products).

3. Horizontal Members

- CRCA Rectangular pipe of cross-section of 60 x 30 mm and 2 mm thickness shall be used with 70-80 microns pure epoxy powder coating.
- Horizontal members shall be connected using C-clamps/U-clamps with two adjacent C-Frames at a distance of 900 mm together and that shall form the skeletal structure of the work bench on which the worktop can be placed.

4. Removable Back Panels

- Removable back panels cover the service lines that run behind them.
- These should be easily removable (unclipped) and the service line be accessed for maintenance. This allows the equipment on the workbench to remain undisturbed.
- They should be made of CRCA sheet 1.2 mm of thickness and provided with 70-80 microns pure epoxy powder coating.

5. Side Cover and Filler Panels

- All side cover and filler panels should be made from CRCA sheet of 1.2 mm thickness with 70 – 80 microns pure epoxy powder coating.

6. Worktop

- Jet Black Granite worktop should be of 18 ± 2 mm thick.
- The front edge of the granite must be chamfered properly at an angle of 28 degrees and should be properly smoothed.
- The bottom of the worktop should be polished and there should be a V-groove throughout the length of the exposed edges to protect the cabinets from coming in contact with the spillages.
- The overhang for the worktop is 25 mm at the front side and 30 mm at the sides.
- The backing material used is a neoprene mat of 6 mm thickness.
- All front corners shall be smoothly curved; and sharp corners should be avoided.

- Tabletop and other components should have a colour approved by IIT Tirupati.

Item No-6 : TABLE WITH GRANITE TOP (SPECIAL TABLE 1) WITHOUT TRUNKING AND WITHOUT LAN PORT

1. Overall Dimensions:

Length – 1219 mm ± 10 mm
 Width – 1219 mm ± 10 mm
 Height – 914 mm ± 10 mm

2. C-Frame System

- All C-Frames assemblies should be manufactured from standard hollow metal sections; conforming to I.S. Code 7138:1993 (Indian Standard specification for steel tubes for furniture).
- All sheet metal components should be of CRCA conforming to IS Code 513:2016.
- C-frame should be constructed from a rectangular pipe with a cross section of 60 mm x 30 mm and should be 2 mm thick and should be without a vertical front leg to give a clean look.
- This shall provide more knee space or leg space and would facilitate uninterrupted lateral movement of the under-bench units within the bench run.
- The C-frame legs should be supplied with adjustable PVC nylon bush with high impact and vibration resistance (tolerance from -5 mm to +20 mm) to correct the unevenness of flooring.
- The structure should have a removable back panel to provide access for maintenance throughout the length of the table. The C-frame shall also have skirting at back bottom side.
- All framework should be pre-treated with superior pure epoxy powder coated finish.
- The C-Frames should be for Mobile Storage Cabinets that can be moved out of the workbench for better flexibility in design.
- All steel components need to be pre-treated with an acid wash, anticorrosive treatment prior to powder coating.
- The entire framework should be done with pure 70-80 microns epoxy powder coating.
- Scratch-resistant Powder Coat of required colour for all metal approved by IIT Tirupati shall be provided.
- All the welding should be done using the electro-welding process only.
- The standard of the table should be as per BIFMA X5.5-2021 (National Standard for Office and Institutional Furnishings - Desk and Table Products).

3. Horizontal Members

- CRCA Rectangular pipe of cross-section of 60 x 30 mm and 2 mm thickness shall be used with 70-80 microns pure epoxy powder coating.
- Horizontal members shall be connected using C-clamps/U-clamps with two adjacent C-Frames at a distance of 1200 mm together and that shall form the skeletal structure of the work bench on which the worktop can be placed.

4. Removable Back Panels

- Removable back panels cover the service lines that run behind them.
- These should be easily removable (unclipped) and the service line be accessed for maintenance. This allows the equipment on the workbench to remain undisturbed.
- They should be made of CRCA sheet 1.2 mm of thickness and provided with 70-80 microns pure epoxy powder coating.

5. Side Cover and Filler Panels

- All side cover and filler panels should be made from CRCA sheet of 1.2 mm thickness with 70 – 80 microns pure epoxy powder coating.

6. Worktop

- Jet Black Granite worktop should be of 18 ± 2 mm thick.
- The front edge of the granite must be chamfered properly at an angle of 28 degrees and should be properly smoothed.
- The bottom of the worktop should be polished and there should be a V-groove throughout the length of the exposed edges to protect the cabinets from coming in contact with the spillages.
- The overhang for the worktop is 25 mm at the front side and 30 mm at the sides.
- The backing material used is a neoprene mat of 6 mm thickness.
- All front corners shall be smoothly curved; and sharp corners should be avoided.
- Tabletop and other components should have a colour approved by IIT Tirupati.

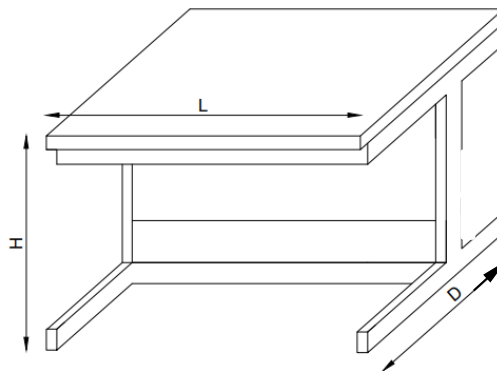

Fig (ii) C-Frame Table without Electrical Trunking

Item No-7 : TABLE WITH GRANITE TOP (SPECIAL TABLE 2) WITHOUT TRUNKING AND WITHOUT LAN PORT

1. Overall Dimensions:

Length	– 914 mm \pm 10 mm
Width	– 914 mm \pm 10 mm
Height	– 914 mm \pm 10 mm

2. C-Frame System

- All C-Frames assemblies should be manufactured from standard hollow metal sections; confirming to I.S. Code 7138:1993 (Indian Standard specification for steel tubes for furniture).
- All sheet metal components should be of CRCA confirming to IS Code 513:2016.
- C-frame should be constructed from a rectangular pipe with a cross section of 60 mm x 30 mm and should be 2 mm thick and should be without a vertical front leg to give a clean look.
- This shall provide more knee space or leg space and would facilitate uninterrupted lateral movement of the under-bench units within the bench run.
- The C-frame legs should be supplied with adjustable PVC nylon bush with high impact and vibration resistance (tolerance from -5 mm to +20 mm) to correct the unevenness of flooring.
- The structure should have a removable back panel to provide access for maintenance throughout the length of the table. The C-frame shall also have skirting at back bottom side.
- All framework should be pre-treated with superior pure epoxy powder coated finish.
- The C-Frames should be for Mobile Storage Cabinets that can be moved out of the workbench for better flexibility in design.
- All steel components need to be pre-treated with an acid wash, anticorrosive treatment prior to powder coating.
- The entire framework should be done with pure 70-80 microns epoxy powder coating.
- Scratch-resistant Powder Coat of required colour for all metal approved by IIT Tirupati shall be provided.
- All the welding should be done using the electro-welding process only.
- The standard of the table should be as per BIFMA X5.5-2021 (National Standard for Office and Institutional Furnishings - Desk and Table Products).

3. Horizontal Members

- CRCA Rectangular pipe of cross-section of 60 x 30 mm and 2 mm thickness shall be used with 70-80 microns pure epoxy powder coating.
- Horizontal members shall be connected using C-clamps/U-clamps with two adjacent C-Frames at a distance of 900 mm together and that shall form the skeletal structure of the work bench on which the worktop can be placed.

4. Removable Back Panels

- Removable back panels cover the service lines that run behind them.
- These should be easily removable (unclipped) and the service line be accessed for maintenance. This allows the equipment on the workbench to remain undisturbed.
- They should be made of CRCA sheet 1.2 mm of thickness and provided with 70-80 microns pure epoxy powder coating.

5. Side Cover and Filler Panels

- All side cover and filler panels should be made from CRCA sheet of 1.2 mm thickness with 70 – 80 microns pure epoxy powder coating.

6. Worktop

- Jet Black Granite worktop should be of 18 ± 2 mm thick.
- The front edge of the granite must be chamfered properly at an angle of 28 degrees and should be properly smoothed.
- The bottom of the worktop should be polished and there should be a V-groove throughout the length of the exposed edges to protect the cabinets from coming in contact with the spillages.
- The overhang for the worktop is 25 mm at the front side and 30 mm at the sides.
- The backing material used is a neoprene mat of 6 mm thickness.
- All front corners shall be smoothly curved; and sharp corners should be avoided.
- Tabletop and other components should have a colour approved by IIT Tirupati.

Item No-8: TABLE WITH GRANITE TOP (SPECIAL TABLE 3) WITHOUT TRUNKING AND WITHOUT LAN PORT

1. Overall Dimensions:

Length	– 1524 mm \pm 10 mm
Width	– 914 mm \pm 10 mm
Height	– 914 mm \pm 10 mm

2. C-Frame System

- All C-Frames assemblies should be manufactured from standard hollow metal sections; confirming to I.S. Code 7138:1993 (Indian Standard specification for steel tubes for furniture).
- All sheet metal components should be of CRCA confirming to IS Code 513:2016.
- C-frame should be constructed from a rectangular pipe with a cross section of 60 mm x 30 mm and should be 2 mm thick and should be without a vertical front leg to give a clean look.
- This shall provide more knee space or leg space and would facilitate uninterrupted lateral movement of the under-bench units within the bench run.
- The C-frame legs should be supplied with adjustable PVC nylon bush with high impact and vibration resistance (tolerance from -5 mm to +20 mm) to correct the unevenness of flooring.
- The structure should have a removable back panel to provide access for maintenance throughout the length of the table. The C-frame shall also have skirting at back bottom side.
- All framework should be pre-treated with superior pure epoxy powder coated finish.
- The C-Frames should be for Mobile Storage Cabinets that can be moved out of the workbench for better flexibility in design.

- All steel components need to be pre-treated with an acid wash, anticorrosive treatment prior to powder coating.
- The entire framework should be done with pure 70-80 microns epoxy powder coating.
- Scratch-resistant Powder Coat of required colour for all metal approved by IIT Tirupati shall be provided.
- All the welding should be done using the electro-welding process only.
- The standard of the table should be as per BIFMA X5.5-2021 (National Standard for Office and Institutional Furnishings - Desk and Table Products).

3. Horizontal Members

- CRCA Rectangular pipe of cross-section of 60 x 30 mm and 2 mm thickness shall be used with 70-80 microns pure epoxy powder coating.
- Horizontal members shall be connected using C-clamps/U-clamps with two adjacent C-Frames at a distance of 1500 mm together and that shall form the skeletal structure of the work bench on which the worktop can be placed.

4. Removable Back Panels

- Removable back panels cover the service lines that run behind them.
- These should be easily removable (unclipped) and the service line be accessed for maintenance. This allows the equipment on the workbench to remain undisturbed.
- They should be made of CRCA sheet 1.2 mm of thickness and provided with 70-80 microns pure epoxy powder coating.

5. Side Cover and Filler Panels

- All side cover and filler panels should be made from CRCA sheet of 1.2 mm thickness with 70 – 80 microns pure epoxy powder coating.

6. Worktop

- Jet Black Granite worktop should be of 18 ± 2 mm thick.
- The front edge of the granite must be chamfered properly at an angle of 28 degrees and should be properly smoothed.
- The bottom of the worktop should be polished and there should be a V-groove throughout the length of the exposed edges to protect the cabinets from coming in contact with the spillages.
- The overhang for the worktop is 25 mm at the front side and 30 mm at the sides.
- The backing material used is a neoprene mat of 6 mm thickness.
- All front corners shall be smoothly curved; and sharp corners should be avoided.
- Tabletop and other components should have a colour approved by IIT Tirupati.

Item No-9 : TABLE WITH GRANITE TOP (SPECIAL TABLE 4) WITHOUT TRUNKING AND WITHOUT LAN PORT

1. Overall Dimensions:

Length – 1524 mm \pm 10 mm

Width – 914 mm ± 10 mm
Height – 750 mm ± 10 mm

2. C-Frame System

- All C-Frames assemblies should be manufactured from standard hollow metal sections; confirming to I.S. Code 7138:1993 (Indian Standard specification for steel tubes for furniture).
- All sheet metal components should be of CRCA confirming to IS Code 513:2016.
- C-frame should be constructed from a rectangular pipe with a cross section of 60 mm x 30 mm and should be 2 mm thick and should be without a vertical front leg to give a clean look.
- This shall provide more knee space or leg space and would facilitate uninterrupted lateral movement of the under-bench units within the bench run.
- The C-frame legs should be supplied with adjustable PVC nylon bush with high impact and vibration resistance (tolerance from -5 mm to +20 mm) to correct the unevenness of flooring.
- The structure should have a removable back panel to provide access for maintenance throughout the length of the table. The C-frame shall also have skirting at back bottom side.
- All framework should be pre-treated with superior pure epoxy powder coated finish.
- The C-Frames should be for Mobile Storage Cabinets that can be moved out of the workbench for better flexibility in design.
- All steel components need to be pre-treated with an acid wash, anticorrosive treatment prior to powder coating.
- The entire framework should be done with pure 70-80 microns epoxy powder coating.
- Scratch-resistant Powder Coat of required colour for all metal approved by IIT Tirupati shall be provided.
- All the welding should be done using the electro-welding process only.
- The standard of the table should be as per BIFMA X5.5-2021 (National Standard for Office and Institutional Furnishings - Desk and Table Products).

3. Horizontal Members

- CRCA Rectangular pipe of cross-section of 60 x 30 mm and 2 mm thickness shall be used with 70-80 microns pure epoxy powder coating.
- Horizontal members shall be connected using C-clamps/U-clamps with two adjacent C-Frames at a distance of 1500 mm together and that shall form the skeletal structure of the work bench on which the worktop can be placed.

4. Removable Back Panels

- Removable back panels cover the service lines that run behind them.
- These should be easily removable (unclipped) and the service line be accessed for maintenance. This allows the equipment on the workbench to remain undisturbed.
- They should be made of CRCA sheet 1.2 mm of thickness and provided with 70-80 microns pure epoxy powder coating.

5. Side Cover and Filler Panels

- All side cover and filler panels should be made from CRCA sheet of 1.2 mm thickness with 70 – 80 microns pure epoxy powder coating.

6. Worktop

- Jet Black Granite worktop should be of 18 ± 2 mm thick.
- The front edge of the granite must be chamfered properly at an angle of 28 degrees and should be properly smoothed.
- The bottom of the worktop should be polished and there should be a V-groove throughout the length of the exposed edges to protect the cabinets from coming in contact with the spillages.
- The overhang for the worktop is 25 mm at the front side and 30 mm at the sides.
- The backing material used is a neoprene mat of 6 mm thickness.
- All front corners shall be smoothly curved; and sharp corners should be avoided.
- Tabletop and other components should have a colour approved by IIT Tirupati.

Item No-10 : GRANITE TABLE WITH SINK (WITHOUT TRUNKING AND LAN PORT)

1. Overall Dimensions:

Length	– 1524 mm \pm 10 mm
Width	– 914 mm \pm 10 mm
Height	– 914 mm \pm 10 mm

2. C-Frame System

- All C-Frames assemblies should be manufactured from standard hollow metal sections; confirming to I.S. Code 7138:1993 (Indian Standard specification for steel tubes for furniture).
- All sheet metal components should be of CRCA confirming to IS Code 513:2016.
- C-frame should be constructed from a rectangular pipe with a cross section of 60 mm x 30 mm and should be 2 mm thick and should be without a vertical front leg to give a clean look.
- This shall provide more knee space or leg space and would facilitate uninterrupted lateral movement of the under-bench units within the bench run.
- The C-frame legs should be supplied with adjustable PVC nylon bush with high impact and vibration resistance (tolerance from -5 mm to +20 mm) to correct the unevenness of flooring.
- Drainage gradient should be well adjusted throughout the length of table and should have horizontal supports for drainage systems.
- The structure should have a removable back panel to provide access for maintenance throughout the length of the table. The C-frame shall also have skirting at back bottom side.
- All framework should be pre-treated with superior pure epoxy powder coated finish.

- The C-Frames should be for Mobile Storage Cabinets that can be moved out of the workbench for better flexibility in design.
- All steel components need to be pre-treated with an acid wash, anticorrosive treatment prior to powder coating.
- The entire framework should be done with pure 70-80 microns epoxy powder coating.
- Scratch-resistant Powder Coat of required colour for all metal approved by IIT Tirupati shall be provided.
- All the welding should be done using the electro-welding process only.
- The standard of the table should be as per BIFMA X5.5-2021 (National Standard for Office and Institutional Furnishings - Desk and Table Products).

3. Horizontal Members

- CRCA Rectangular pipe of cross-section of 60 x 30 mm and 2 mm thickness shall be used with 70-80 microns pure epoxy powder coating.
- Horizontal members shall be connected using C-clamps/U-clamps with two adjacent C-Frames at a distance of 1500 mm together and that shall form the skeletal structure of the work bench on which the worktop can be placed.

4. Removable Back Panels

- Removable back panels cover the service lines that run behind them.
- These should be easily removable (unclipped) and the service line be accessed for maintenance. This allows the equipment on the workbench to remain undisturbed.
- They should be made of CRCA sheet 1.2 mm of thickness and provided with 70-80 microns pure epoxy powder coating.

5. Side Cover and Filler Panels

- All side cover and filler panels should be made from CRCA sheet of 1.2 mm thickness with 70 – 80 microns pure epoxy powder coating.

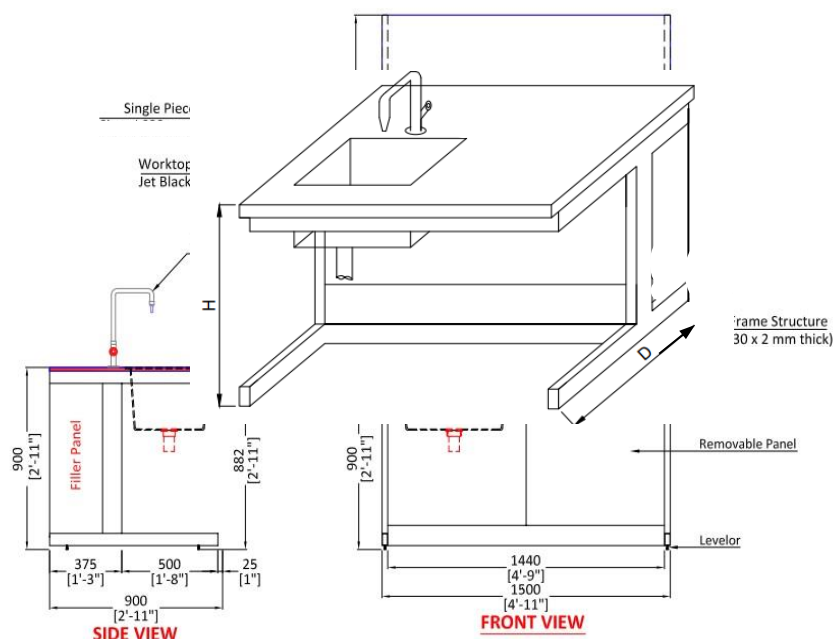

Fig. (iii) C-Frame Table with sink

6. Worktop

- Jet Black Granite worktop should be of 18 ± 2 mm thick.
- The front edge of the granite must be chamfered properly at an angle of 28 degrees and should be properly smoothed.
- The bottom of the worktop should be polished and there should be a V-groove throughout the length of the exposed edges to protect the cabinets from coming in contact with the spillages.
- The overhang for the worktop is 25 mm at the front side and 30 mm at the sides.
- The backing material used is a neoprene mat of 6 mm thickness.
- All front corners shall be smoothly curved; and sharp corners should be avoided.
- Tabletop and other components should have a colour approved by IIT Tirupati.

7. Polypropylene Moulded Sinks

- Made up of 5 mm thick high density and elastic poly propylene with good resistance to organic solvents.
- Sink to be provided with flexible connector and anti-syphon bottle trap.
- Standard bowl size (L x W x D) is 500 x 300 x 200 mm (Tolerance ± 10 mm).
- Faucet should be 3-way type faucet of approved make.

Item No. 11 UNDER BENCH TROLLEY

The complete GI material of cabinet in a weld less construction is pre-treated (degreased, Zinc phosphated) and epoxy powder coated for better corrosion resistance. The thickness of powder coat shall be 70-80 microns conforming to relevant BIS code, which accordingly passes the test of Salt Spray for 1000 hours and having the scratch hardness of 3 kgs.. The cabinet should be excellent corrosion resistant and spillage proof against acid and alkaline solutions. Cabinet should be of square non-sharp edge construction. Module sheet thickness should be 1.2 mm or more. The cabinet should consist of one drawer and two shutters as per the diagram. Drawer tray should be of single piece construction. The drawer trays should be mounted on telescopic slides capable of bearing a load of 45 kg. Castor wheels with a locking system are to be provided. Provide Auto-closing type hinges in SS construction (hidden-type) with 180° opening. Should facilitate an adjustable shelves system. Aluminium flush handles are to be provided. Provide Lock with two keys each for drawer and shutter.

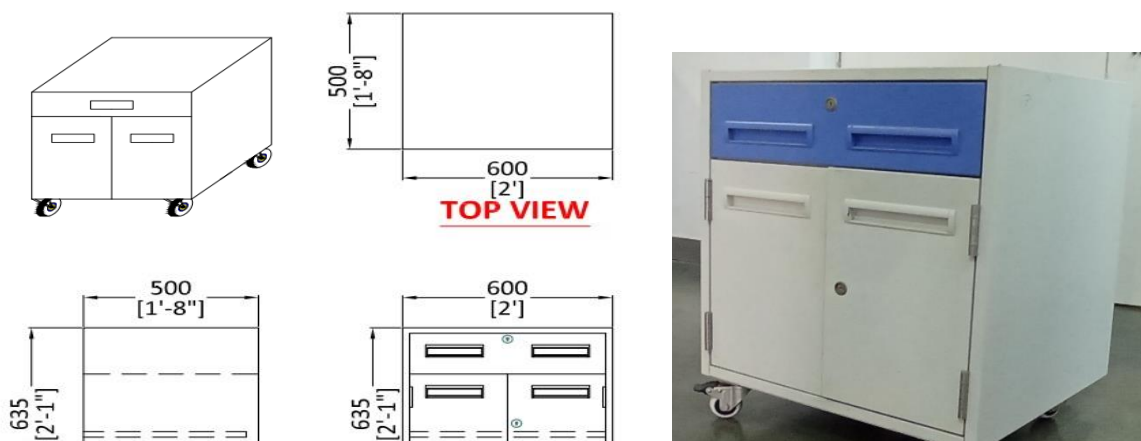

Fig. (iv) Under bench trolley

Construction Detail:

- Cabinet end panels; min. 1.2 mm thick GI Sheet
- Cabinet rear panel and top panel; min. 1.2 mm thick GI sheet
- Cabinet base skid; 1.2 mm thick GI Sheet
- Cabinet drawers; 1.2 mm thick GI Sheet
- Cabinet shutters & drawer front panels; double skin const. min 0.8 mm thick GI sheet
- Cabinet main frame structure and drawer slide rails, 1.6 mm thick GI Sheet
- Suitable 4 Nos of castor wheel in each cabinet (Front 2 Nos are lockable and Rear 2 Nos are un-lockable)

Item No. 12 DOUBLE DOOR WALL MOUNTED STORAGE CABINET

The cabinets should be suitable for mounting on wall. The cabinets shall be fabricated out of Galvanized Iron (Zinc coated). Cabinets should be provided with 1 adjustable shelf. Proper design, stiffening/ structural members should be provided for strength and rigidity. Front door of the cabinet shall be in twin door design having glass panel with metallic frame in Galvanized Iron construction.

No of Shelves: 1 shelf, forming 2 compartments. Shelf should be adjustable in height.

Construction Detail:

- End Panel, Top Panel & Bottom Panel: 1.2 mm thick Galvanized Iron Sheet
- Rear Panel: 1.2 mm Galvanized Iron Sheets
- Front door: 5 mm thick transparent glass with metallic frame in GI construction
- Shelf: 1.2 mm thick GI sheet
- Door Supporting frames: 1.6 mm thick GI Sheet
- Door Hinges: Knuckle and Barrel type SS hinges.
- Door handles: SS 304 const or better.
- Lock: - With two keys for doors

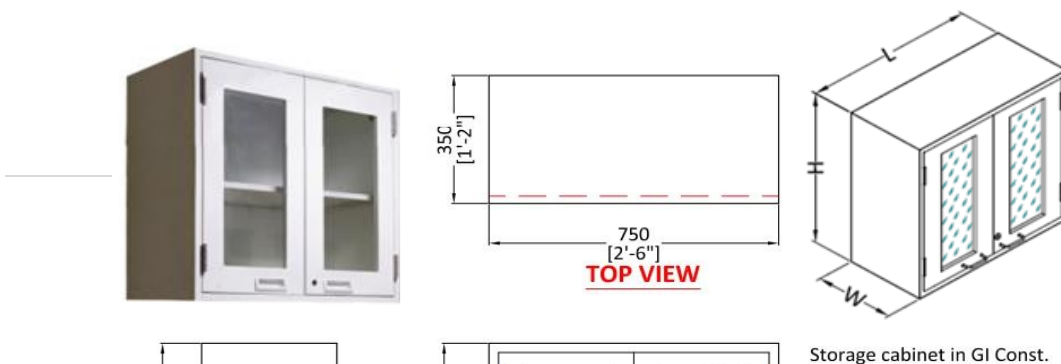

Fig. (iv) Double door wall mounted storage Cabinet

Item No. 13: STUDENT CHAIRS (Type 1-UG Labs)

The chair should be capable of carrying load of 150 kgs.

- The seat is to be made up of 1.2 ± 0.1 cm thick flat plywood and with moulded Polyurethane foam and are-upholstered with replaceable synthetic leather covers.
- The back foam is to be designed with contoured Lumbar support for extra comfort. The upholstery is available in synthetic leather.
- HR polyurethane foam moulded with density of 45 ± 2 kg/m³ and Hardness load 16 ± 2 kgf as per IS : 7888 for 25% compression shall be provided.
- The manual height adjustment shall be done with knob and to be locked at the most comfortable position. Overall height without extension 103 cm (Approximately) with 10 cm height adjustment facility with hand rest.
- The five -prong pedestal is to be fabricated from 0.2 ± 0.02 cm thick HR sheet powder coated (DFT 40-60 microns) and fitted with an injection moulded black Polypropylene Hub Cap and 5 nos. twin wheel castors. The pedestal is 55.0 ± 0.5 cm pitch-circle diameter (65.0 ± 1.0 cm with castors). Circular foot -ring of diameter 52.0 ± 0.2 cm made up of dia $1.9 \pm 0.2 \times 0.12 \pm 0.0096$ cm thick MS ERW Tube for foot support in High-base stool.
- Injection moulded twin wheel castors in Black Nylon shall be provided.



Fig. (v) UG Lab Student Chair

Item No. 14: STUDENT CHAIRS (TYPE 2 - RESEARCH LABS)

Overall Dimensions of Chair:

- a. Seat Height - 450 mm \pm 5mm
- b. Overall Height - 920 mm \pm 5mm
- c. Seat width - 480 mm \pm 5mm
- d. Seat depth - 480 mm \pm 5mm
- e. Backrest height - 570 mm \pm 5mm
- f. Backrest width - 440 mm \pm 5mm

- The chair should be capable of carrying load of 150 kgs.
- Seat assembly should be 12 \pm 1mm thick hot-pressed plywood upholstered with fabric upholstery covers and moulded polyurethane foam.
- Backrest should be made up of upholstered using double-layer spacer mesh Fabric with high tenacity yarn. The backrest is made of one-piece injection moulded frame. The backrest should be symmetrical lumber support.
- HR polyurethane foam should be moulded with density of 45 \pm 2 kg/m³ and hardness load 16 \pm 2 kgf for 25% compression.
- One-piece armrests should be injection moulded from black copolymer polypropylene.
- Center-tilt mechanism should be designed with the following features:
 - a. 360° revolving type
 - b. 17° \pm 2° maximum tilt on a pivot at the Centre
 - c. Upright position locking
 - d. Tilt tension adjustment
- Pneumatic height adjustment has an adjustment stroke of 120 \pm 5mm.
- Pedestal should be injection moulded in black 33% glass filled nylon and 5 Nos. Twin wheel castors. The pedestal should be 620 \pm 5 mm. Pitch-center dia. (720 \pm 10 mm with castors)
- Twin wheel castors: The twin wheel castors should be injection moulded in black nylon. Additional information: Office Seating should be as per ANSI/BIFMA X5.1



Fig. (vi) Research Lab Student Chair

Important Instruction:

The Item No.1 to 10 combined as set No.1, Item No. 11 as set no.2, Item No. 12 as set no.3, Item No. 13 & 14 combined as set No. 4 and the evaluation will be on the basis of set wise. Based on the eligibility criteria, Bidder (s) can quote for one or more sets (s). L1 will be decided on Set-wise i.e.

***Set No- 1 [Item No.1 to 10]
Set No- 2 [Item No.11]
Set No- 3 [Item No.12]
Set No- 4 [Item No. 13&14]

- All offered products' technical Specifications and Brochures are to be submitted along with the Technical Bid.
- The detailed scope of coverage of the Warranty shall be provided in the compliance statement -Annexure-VII.

3. TENDER FEE & BID SECURITY DECLARATION DETAILS:

3.1 A tender Fee of Rs.2500/- (Rupees Two thousand five hundred only) should be submitted through ECS (Bank transfer / NEFT / RTGS) in favor of the Indian Institute of Technology Tirupati.

3.2 Bank A/c Details for crediting Tender Fee:

Name : Indian Institute of Technology Tirupati Main Account
Bank : State Bank of India
Account No : 35523338208
IFSC Code : SBIN0006677

3.3 Tender Fee and Bid Security Exemption:

I) Micro and Small Enterprises (MSEs):

Micro and Small Enterprises (MSEs) as defined in MSE Procurement Policy issued by Department of Micro, Small and Medium Enterprises (MSME) for **goods produced and services rendered**, are exempted from Tender fee and Bid Security. However, they must enclose **valid self-attested registration certificate(s)** and the tender to this effect.

Accordingly, MSEs shall be required to submit valid **Udyam Registration Certificate** for availing benefit under MSE Procurement Policy.

The benefit as above to MSEs shall be available only for Goods produced and services rendered by MSEs. However, traders are excluded from the purview of MSE Procurement Policy.

II) Startup (s):

Startup(s) as recognized by **Department for Promotion of Industry and Internal Trade (DPIIT)**, Govt. of India, are exempted from Tender fee and Bid Security. However, they have to enclose ***valid self-attested registration certificate(s)*** along with the tender to this effect.

Eligible MSE and startup bidders who seeks exemption from Tender fee/Bid Security as per clause no. (c) above, if they withdraw or modify their bids during the period of validity, or if they are awarded the contract and they fail to sign the contract, or to submit a performance security before the deadline defined in the request for bids document, they will be suspended for the period of three years or as decided by the competent authority from being eligible to submit bids for contracts with the entity that invited the bids.

3.4 Other than eligible MSE and Startup bidders, Bid Security Declaration:

Bidders should have to submit the Bid Security Declaration (As per the format attached in annexure-II) in duly filled and signed condition.

3.5 The Bidders will have to upload scanned copy of Payment details towards tender fee and the same will be accepted only on verification and confirmation by the Institute. Any delay in credit will not be entertained by the Institute. **(As per the format attached in Annexure – I)**

4. ELIGIBILITY CRITERIA

4.1 Other Important Documents (OIDs)

Firm Incorporation Certificate, PAN details, GST details are to be provided.

4.2. Statutory Documents:

- I) The Bidder should give self-declaration certificate for acceptance of all terms & conditions of tender documents. A duly completed certificate to this effect is to be submitted as per the Annexure-I.
- II) The firm should not be in active debarred list by any Central / State Government / Public Undertaking / Institute and no criminal case registered / pending against the firm or its owner / partners anywhere in India. A duly completed certificate to this effect is to be submitted as per Annexure-III.

III) **Experience and Past Performance:**

The Bidder should submit list of clientele to whom identical or similar furniture have supplied during past five financial years **i.e. during 2017-18 to 2021-22** with their contact details along with documentary evidence such as Purchase Orders executed along with technical specifications, completion certificates from the client, etc. are to be submitted as per the **Annexure-IV**.
(On-going works will not be considered for the Technical evaluation)

At least in any one of the calendar years (2018-2022), the number of items supplied should be more than items mentioned in tender enquiry (Pl. submit the proof of supply of identical or similar furniture).

IV) The Annual Turnover should be at least **Rs. 3.5 Crores** and be profitable during each of the previous three financial years **i.e. during 2018-19 to 2020-21 or 2019-20 to 2021-22**. Audited financial Statements or Financial Statements showing turnover duly signed by a Chartered Accountant are to be submitted as per the **Annexure-V**.

V) **The Bidder should be a Class-I / Class-II Local Supplier meeting minimum 20% local content clause in line with the Public Procurement (Preference to Make in India) Order 2017 No. P-45021/2/2017-PP (BE-II) dated 04 Jun 2020 as amended from time to time. A Self-Declaration Certificate regarding “Class-I/Class-II Supplier” for the tendered items as per the Annexure-V is to be submitted.**

As per the OM of Department of Promotion for Industry and Internal Trade No. P-45021/102/2019-BE-II-Part(1) dated: 04.03.2021. The bidders can't claim themselves as Class-I local suppliers/Class-II local suppliers by claiming the services such as transportation, insurance, installation, commissioning, training and after sales service support like AMC/CMC etc. as local value addition.

- a. 'Local Content' means the amount of value added in India which shall, unless otherwise prescribed by the Nodal Ministry, be the total value of the item procured (excluding net domestic indirect taxes) minus the value of imported content in the item (including all custom duties) as a proportion of the total value, in percent.
- b. 'Class-I local supplier' means a supplier or service provider, whose goods, services or works offered for procurement, has local content equal to or more than 50% as defined under this order.
- c. 'Class-II local supplier' means a supplier or service provider, whose goods, services or works offered for procurement, has minimum local content of 20% but less than 50%, as defined under this order.

- d. 'Non-local supplier' means a supplier or service provider, whose goods, services or works offered for procurement, has local content less than 20%, as defined under this order.
- e. Complaint redressal mechanism: In case any complaint received by the procuring agency or the concerned Ministry/Department against the claim of a bidder regarding local content/domestic value addition in an electronic product, the same shall be referred to STQC.
- f. The Bidder shall be required to furnish the necessary documentation in support of the domestic value addition claimed in an electronic product to STQC. If no information is furnished by the Bidder, such laboratories may take further necessary action, to establish the bonafides of the claim.
- g. A complaint fee of Rs. 2 lakh or 1% of the value of the domestically manufactured products being procured (subject to a maximum of Rs.5 lakh), whichever is higher, to be paid by Demand Draft to be deposited with STQC. In case, the complaint is found to be incorrect, the complaint fee shall be forfeited. In case, the complaint is upheld and found to be substantially correct, deposited fee of the complainant would be refunded without any interest.
- h. False declarations will be in breach of the Code of Integrity under Rule 175 (1)(i)(h) of the General Financial Rules for which a bidder or its successors can be debarred for up to two years as per Rule 151 (iii) of the General Financial Rules along with such other actions as may be permissible under law.

VI) The Bidder should be OEM or OEM authorized Dealers / Channel partners / Distributors of reputed brand having authorization for sales and after sales support. Valid OEM authorization letter is required to participate in this tender.

VII) Prior Registration and / or Screening of bidders:

Any bidder from a country which shares a land border with India will be eligible to bid in this tender only if the Bidder registered with the competent authority. **The concerned Bidder (s) are required to attach the relevant valid Registration Certificate along with the bid for consideration.**

“Bidder” (including the term ‘tenderer’, consultant or service provider in certain contexts) means any person or firm or company, including any member of a consortium or joint venture (that is an association of several persons, or firms or companies), every artificial juridical person not falling in any of the descriptions of bidders stated hereinbefore, including any agency branch or office controlled by such person, participating in a procurement process.

“Bidder from a country which shares a land border with India” for the purpose of this Order means :-

- An entity incorporated, established or registered in such a country; or
- A subsidiary of an entity incorporated, established or registered in such a country or
- An entity substantially controlled through entities incorporated, established or registered in such a country; or
- An entity whose beneficial owner is situated in such a country; or
- An Indian (or other) agent of such an entity; or
- A natural person who is a citizen of such a country; or
- A consortium of joint venture where any member of the consortium or joint venture falls under any of the above.

The detailed terms & conditions issued from time to time in this regard by Government of India will be applicable.

VIII) Authorized Representatives:

Bids of bidders quoting as authorised representative of a principal manufacturer would also be considered to be qualified, provided:

- (i) Their principal manufacturer meets all the criteria above without exemption, and
- ii) The principal manufacturer furnishes a legally enforceable tender-specific authorisation assuring full guarantee and warranty obligations as per the general and special conditions of contract;
and
- iii) The Bidder himself should have been associated, as authorised representative of the Principal Manufacturer for same set of services as in present bid (supply, installation, satisfactorily commissioning, after sales service as the case may be) for same or similar item for past three years ending on bid opening date.

IX) The should have valid below mentioned certificated

1. SEFA-3 and SEFA-8
2. BIFA X 5.5 2021 for office and Institutional furnishing
3. ISO 9001:2015 for the firm
4. All the component shall confirm to the relevant IS standards specifications

4.3 TECHNICAL CRITERIA

Bidders should comply the specification of the tendered item in all respect. The detailed format is attached at Annexure-VII. The Bidder is to complete the same in all respect and submit accordingly

5. FINANCIAL BID DETAILS

5.1 Financial bid i.e. BOQ given with tender (in **Excel format**) to be downloaded first and uploaded after filling all relevant information strictly as per the format failing which the offer is liable for rejection. Kindly quote your offer on FOR IIT Tirupati (inclusive of all taxes and charges). **Vendor should quote prices in BOQ only, offers indicating rates anywhere else shall be liable for rejection.**

6. TIME SCHEDULE:

1	Date and time of Online Publication/Download of Tenders	01.05.2023	18.00 hrs
2	Clarifications start date	01.05.2023	18.00 hrs
3	Clarifications end date	15.05.2023	15.00 hrs
4	Uploading of corrigendum after the receipt of clarifications (If any)	16.05.2023	15.00 hrs
5	Bid submission start date & time	02.05.2023	10.00 hrs
6	Bid submission close date & time	24.05.2023	15.00 hrs
7	Closing date & time for submission of EMD/Tender fee	24.05.2023	15.00 hrs
8	Opening of Technical bids	25.05.2023	15.00 hrs

7. AVAILABILITY OF TENDER

The tender document can be downloaded from <http://eprocure.gov.in/eprocure/app> and be submitted only through the same website.

8. BID VALIDITY PERIOD

The bid will remain valid for **120 days** from the date of opening as prescribed by IIT Tirupati. A bid valid for a shorter period shall be rejected, being non-responsive.

9. BID SUBMISSION

9.1 Instruction to Bidder

- I) Bidders are required to enrol on the e-Procurement module of the **Central Public Procurement Portal (URL: <https://eprocure.gov.in/eprocure/app>)** by clicking on the link "**Online Bidder Enrolment**" on the CPP Portal. **The registration is completely free of charge.**
- II) Possession of a valid Class II/III DSC in the form of smart card / e-token is a prerequisite for registration and participating in the bid submission activities. DSCs can be obtained from the authorised certifying agencies recognized by CCA India (e.g. Sify/TCS/nCode/eMudhra etc).

- III) Bidders are advised to register their valid email addresses and mobile numbers as part of the registration process. These would be used for any communication from the CPP Portal.
- IV) A bidder should register only one valid DSC. Please note that the bidders are responsible to ensure that they do not lend their DSCs to others which may lead to misuse.
- V) The Bidders are required to log in to the site through the secured log-in by entering their respective user ID / password and the password of the DSC.
- VI) The CPP portal also has user manuals with detailed guidelines on enrolment and participation in the online bidding process. The user manuals can be downloaded for reference.

9.2 TENDER CLARIFICATION

- I) In case the bidders require any clarification regarding the tender documents, they are requested to contact our office Ph. no: 0877-2503572, Email ID: purchase@iittp.ac.in on or before due date.
- II) Technical and Specifications related Clarifications contact our office No: 0877-2503602 , [Email ID: eutenders@iittp.ac.in](mailto:eutenders@iittp.ac.in) on or before due date.
- III) Any queries relating to the process of online bid submission or queries relating to CPP Portal in general may be directed to the 24x7 CPP Portal Helpdesk.

9.3 ONLINE BID SUBMISSION PROCEDURE

Cover-1: The file should be saved in a PDF version numbered sequentially and should comprise of the following items:

Packet-1:

Duly Completed Scanned PDF copy of, PAN, GST, Firm Registration certificate and Annexure-I to VIII with relevant supporting documents
Only the relevant documents as per the tender clauses are to be uploaded along with duly completed checklist as per the annexure-IX. Uploading of other than the required documents may liable for rejection of the bid.

Cover-2:

A standard BOQ format has been provided in excel format. Bidders are required to download the BOQ excel file and fill their financial offer on the same

BOQ format. After filling the same, submit it online in excel format, without changing the financial template format.

Note:

If the bid is incomplete and / or non-responsive it will be rejected during technical evaluation. The Bidder may not be approached for clarifications during the technical evaluation. So, the bidders are requested to ensure that they provide all necessary details in the submitted bids.

10. BID OPENING

- 10.1 Technical Bids will be opened on **25.05.2023 @ 15.00 Hrs.**
- 10.2 Financial Bids of the eligible bidders will be opened on a later date. The date and time for the opening of Financial Bids will be announced later.
- 10.3 **Bids should be summarily rejected, if tender is submitted other than through online or original tender fee/Bid security declaration are not submitted within stipulated date / time.**

11. BID EVALUATION

- I) **Stage-I Evaluation (Pre-qualification criteria):** In this stage, the received bids will be evaluated by the committee as per the eligibility criteria, terms and conditions of the tender. Only the shortlisted bidders in this stage will be informed for sample piece submission. The shortlisted bidders will have to submit the sample pieces at IIT Tirupati Transit Campus, Yerpedu Manda, Venkatagiri Road, Tirupati District, Andhra Pradesh – 517619 within 15 days of the receipt of mail from IIT Tirupati. The samples received after **15 days** will not be considered for evaluation.
- II) **Stage-II Evaluation (Sample Piece Evaluation):** In this stage, the expert committee will evaluate the received sample pieces as per the tender specifications, terms, and conditions. Bidders whose samples are accepted by the Institute will be treated as technically qualified bidders for consideration of their price bids.
- III) The Commercial Bid with the lowest price will be the highest evaluated bid. Financial bids of the successful bidders will only be opened and orders placed on L1 basis. .
- IV) The shortlisted Bidder will have to submit the samples each 1 No. for the items
 - 1. **Item no. 1:** Granite top work benches (Standard size) (with Trunking) (with 2 LAN ports)
 - 2. **Item no. 11:** Under Bench Trolley
 - 3. **Item no. 12:** Double door Wall mounted storage cabinets
 - 4. **Item no. 13:** Student Chairs (Type 1-UG Labs)
 - 5. **Item no. 14:** Student Chairs (Type 2-Research Labs)
- V) The L1 bidder should visit the site and take actual measurements of the rooms and have a combined meeting with end user for the better understanding.

- VI) The L1 bidder should submit the room wise furniture layout as per the site conditions(details will be given after award of work)
- VII) After the site visit should submit the shop drawing for the furniture layout room wise with in 7 days and it should be approved by IIT Tirupati for the further process of manufacturing.
- VIII) After receiving the Shop drawing approval from IIT Tirupati L1 bidder should produce the sample within 15 days at their factory for inspection and clearance from IITT before manufacturing of bulk quantity
- IX) From the date for factory vist sample confirmation you delivery time will start.

11.1 Purchase Preference

I) Micro and Small Enterprises (MSEs):

Micro and Small Enterprises (MSEs) as defined in MSE Procurement Policy issued by Department of Micro, Small and Medium Enterprises (MSME) **for goods produced and services rendered**, may be provided following purchase preference:

Item wise Quantity	Price Quoted by MSE	How the tender shall be finalized
Cannot be split	L1	Full Order on MSE
Cannot be split	Not L1 but within L1 + 15%	Full Order on MSE subject to matching L1 Price

II) Preference to Make in India

- a) In procurement goods or works which are covered under by para 3(b) of the extant Public Procurement (Preference to Make in India) Order 2017 dated 04 June 2020 and which are **divisible** in nature, the “Class-I Local Supplier” shall get purchase preference over “Class-II Local Supplier” as well as “Non-Local Supplier” as per following procedure:
 - i) **Among all qualified bids, the lowest bid will be termed as L1. If L1 is** “Class-I Local Supplier”, the contract for full quantity will be awarded to L1.
 - ii) **If L1 bid is not a** “Class-I Local Supplier”, 50% of the order quantity shall be awarded to L1. Thereafter, the lowest Bidder among the “Class-I Local Supplier” will be invited to match L1 price for the remaining 50% quantity subject to the Class-I Local Supplier’s quoted price falling within the margin of L1 + 20%, and contract for that quantity shall be awarded to such “Class-I Local Supplier” subject to matching the L1 price. In case such lowest eligible “Class-I Local Supplier” fails to match L1 price or accepts less than the offered quantity, the next higher “Class-I Local Supplier”

within the margin of L1 + 20% shall be invited to match the L1 price for remaining quantity and so on, and contract shall be awarded accordingly. In case some quantity is still left uncovered on Class-I local suppliers, then such quantity may be ordered on the L1 Bidder.

- b) In procurement goods or works which are covered under by para 3(b) of the extant Public Procurement (Preference to Make in India) Order 2017 dated 04 June 2020 and which are **not divisible** in nature, and in procurement of services where the bid is evaluated on price alone, the “Class-I Local Supplier” shall get purchase preference over “Class-II Local Supplier” as well as “Non-Local Supplier” as per following procedure:
- i) **Among all qualified bids, the lowest bid will be termed as L1. If L1 is “Class-I Local Supplier”, the contract will be awarded to L1.**
 - ii) **If L1 is not a “Class-I Local Supplier”, the lowest Bidder among the Class-I Local Supplier, will be invited to match the L1 price subject to Class-I Local Supplier’s quoted price falling within the margin of L1 + 20%, the contract shall be awarded to such Class-I Supplier subject to matching the L1 price.**
 - iii) **In case such lowest eligible Class-I Local Supplier fails to match the L1 price, the “Class-I Local Supplier” with the next higher bid within the margin of L1 + 20% shall be invited to match the L1 price and so on and contract shall be awarded accordingly. In case none of the of Class-I Local Supplier within the margin of L1 + 20%, the contract may be awarded to the L1 Bidder.**
 - iv) **Class-II Local Supplier will not get purchase preference.**

12. PAYMENT TERMS

No advance payment will be made in any case. Bills in Duplicate should be sent and the payment shall be released generally within 30 days, only after it is ensured that the items / quality of the items supplied are to the entire satisfaction of IIT Tirupati and completed the entire work within the stipulated delivery schedule. If any item is found defective, or not of the desired quality etc., the same should be replaced by the firm(s) immediately for which no extra payment shall be made.

13. WARRANTY OF QUALITY AND QUANTITY

13.1 The awardee shall give **minimum 3-year onsite warranty for all items** on successful completion of supply, and acceptance of supplied items.

13.2 The awardee shall give warranty that all items are as per specification(s), conforming to the specified design and there are no defects in the process of manufacturing, packaging, transportation and delivery.

13.3 Upon receipt of notice from IIT Tirupati for defective material, the firm shall **within 15 days** of receipt of the notice, replace the defective material, free of cost at the destination. The firm shall take over the defective material at the time of their replacement. No claim whatsoever shall lie on IIT Tirupati for the replaced goods thereafter. Suppose the firm fails to replace the defective goods within a reasonable period. In that case, IIT Tirupati may take such remedial actions as necessary, at the company's risk and expense.

14. LIQUIDATED DAMAGES

In case of delay in Supply by the stipulated date, IIT Tirupati reserves the right of imposing penalty @0.5% per week on the value of the undelivered items subject to maximum 10% of the cost of undelivered items.

15. DELIVERY SCHEDULE

15.1 The successful Bidder should execute the order successfully i.e. Supply, Installation of the ordered item within 12 weeks (84 days) at IIT Tirupati Permanent campus (Department block-2 & 1 (G+3), Venkatagiri Road, Yerpedu Mandal, Tirupati District from the date of sample approved at the factory. In case of any damage/Broken/Expired items found, the item(s) should be replaced **within 15 days** at IIT Tirupati. The Bidder has to make own arrangement for unloading and positioning of items at the desired location of IIT.

15.2 The bidders is responsible for the delivery, installation at desired locations floor wise.

16. PERFORMANCE SECURITY DETAILS

16.1 The successful tenderer will have to deposit the performance security valid for **39 Months** in the form of DD / TDR / FDR / Bank Guarantee **@10% of the total order value** at the earliest from the date of issue of the award letter. IIT Tirupati will pay no interest on the deposit.

16.2 Performance Security will be refunded to the supplier, after it duly performs and completes the contract/warranty period in all respects.

16.3 Performance Security will be forfeited if the firm fails to perform/abide by any of the terms or conditions of the contract.

16.4 In case, the firm fails to execute the order successfully, within specified delivery period, the same goods/items will be procured from open market and

the difference of cost, if any, will be recovered from Performance Security or from pending bill(s) of the defaulting firm or from both in case the recoverable amount exceeds the amount of Performance Security.

17. INTEGRITY PACT:

- a. The integrity pact (IP) envisages an agreement between the prospective bidders/ vendors with the buyer committing the persons/ officials of both the parties with the aim not to exercise any corrupt influence on any aspect of the contract. **Only those bidders/ vender who are willing to enter into such an integrity pact with the purchase would be competent to participate in the bidding. In other words, entering into this Pact would be a preliminary qualification. The bidder should give self-declaration certificate for acceptance and compliance with the Integrity Agreement as per Annexure XI.**
- b. Any violation of the Integrity Pact would entail disqualification of the bidders and exclusion from future business dealings, as per the existing provisions of GFR, 2017, PC Act, 1988, and other Financial Rules/Guidelines, etc. as may be applicable to the organization concerned
- c. The integrity pact would be effective from the date of invitation of bids till the complete execution of the contract.
- d. The model format of Integrity Pact(IP) is at **Annexure-XII**

18. TERMS AND CONDITIONS

18.1 Termination for Insolvency

- I) The IIT Tirupati may at any time terminate the Contract by giving a written notice to the awarding firm, without compensation to the firm, if the firm becomes bankrupt or otherwise insolvent as declared by the competent Court, provided that such termination will not prejudice or affect any right of action or remedy, which has accrued or will accrue thereafter to the department.
- II) IIT Tirupati and/or the firm are entitled to withdraw/cancel the rate contract by serving one-month notice on each other. However, once a purchase order is placed on the supplier for supply of a definite quantity in terms of the rate contract during the validity of the rate contract, that purchase order becomes a valid and binding contract.
- III) The courts of Tirupati alone will have the jurisdiction to try any matter, dispute or reference between the parties arising out of this purchase. It is specifically agreed that no court outside and other than Tirupati Court shall have jurisdiction in the matter

18.2 Force Majeure

- I) Should any force majeure circumstances arise, each of the contracting parties be excused for the non-fulfilment or for the delayed fulfilment of any of its contractual obligations, if the affected party within 15 days of its occurrence informs in a written form the other party.
- II) Force Majeure shall mean fire, flood, natural disaster or other acts such as war, turmoil, sabotage, explosions, epidemics, quarantine restriction, strikes, and lockouts i.e. beyond the control of either party.

18.3 Arbitration

- I) All disputes of any kind arising out in connection with the executing the order shall be referred by either party (IIT TIRUPATI or the Bidder) after issuance of 30 days' notice in writing to the other party clearly mentioning the nature of dispute to a single arbitrator acceptable to both the parties. The venue for arbitration shall be IIT TIRUPATI India. The jurisdiction of the courts shall be Tirupati, Andhra Pradesh, India.

18.4 Other Conditions

- I) The Bidder has to upload the relevant & readable files only as indicated in the tender documents. In case of any irrelevant or non-readable files, the bid may be rejected.
- II) IIT Tirupati will not be liable for any obligation or supplies made unless the Official Purchase Order has been placed by the Purchase Department.
- III) IIT Tirupati reserves the right to accept or reject any or all the tenders in part or in full or may cancel the tender, without assigning any reason thereof.
- IV) IIT Tirupati reserves the right to relax / amend / withdraw any of the terms and conditions contained in the Tender Document without assigning any reason thereof. Any inquiry after submission of the quotation will not be entertained.
- V) IIT Tirupati reserves the right to modify/change/delete/add any further terms and conditions prior to issue of purchase order.
- VI) **Repeat Order:** IIT Tirupati reserves the right to place repeat order up to 100% of the quantities within a period of 12 months from the date of successful completion of purchase order at the same rates and terms subject to the condition that there is no downward trend in prices.

To take care of any change in the requirement during the currency of the contract, a plus/minus option clause for 25 per cent is incorporated in the tender document, reserving purchaser's right to increase or decrease the

quantity of the required goods up to that limit without any change in the terms and conditions and prices quoted by the tenderers.

- VII) In case the bidders/successful bidder(s) are found in breach of any condition(s) at any stage of the tender, Performance Security shall be forfeited.
- VIII) False declaration/documents will be in breach of the Code of Integrity under Rule 175(1) (h) of the General Financial Rules for which a bidder or its successors can be debarred for up to two years as per Rule 151 (iii) of the General Financial Rules along with such other actions as may be permissible under law.
- IX) Conditional tenders will not be considered in any case.
- X) In case of doubt in material, the expenditure on testing of equipment will be borne by the tenderer.
- XI) Institute reserve the right to increase/decrease the order quantity at any period of times during the validity of the contract.
- XII) IIT Tirupati may issue amendment/corrigendum to tender documents before due date of submission of bid. Any amendment/corrigendum to the tender document if any, issued by IIT Tirupati will be posted on CPP Portal. For the bidders, submitting bids on downloaded tender document, it is 'bidders' responsibility to check for any amendment/corrigendum on the website of IIT Tirupati or check for the same CPP Portal before submitting their duly completed bids.**

UNDERTAKING

To
The Registrar,
 Indian Institute of Technology
 Yerpedu – Venkatagiri Road, Yerpedu Post,
 Tirupati District, Andhra Pradesh.
 Pincode - 517619.

Tender No. IITT/EU/2023-24/02 dated: 01.05.2023

Name of the Tender/Supply: Notice Inviting Tender for Supply, installation, testing and Commissioning of Lab Furniture.

Sir,

I /we hereby submit our bid for Supply, installation, testing and Commissioning of Lab Furniture.

I/ We enclosed here with the following in favor of Indian Institute of Technology Tirupati towards Tender Fee.

Particular	Amount	Payment Reference Details	Payment Date
Tender Fee (Including Tax)	2500/-		

- I / We hereby reconfirm and declare that I / We have carefully read, understood & complying the above referred tender document including instructions, terms & conditions, scope of work, schedule of quantities and all the contents stated therein. I / We also confirm that the rates quoted by me / us are inclusive of all taxes, duties etc., applicable as on date.
- I /we have gone through all terms and conditions of the tender document before submitting the same.

Date:
Place:

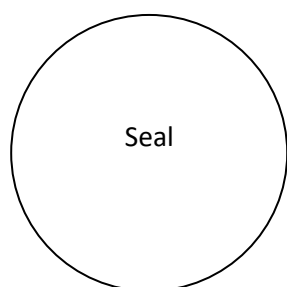

Authorized Signatory

Name:

Designation:
Contact No :

On Company Letter Head

Bid Security Declaration

To
The Registrar,
Indian Institute of Technology
Yerpedu – Venkatagiri Road, Yerpedu Post,
Tirupati District, Andhra Pradesh.
Pincode - 517619.

Tender No. IITT/EU/2023-24/02 dated: 01.05.2023

Name of the Tender/Supply : Notice Inviting Tender for Supply, installation, testing and Commissioning of Lab Furniture.

Sir,

We, the undersigned declare that

1. We understood that, according to the tender conditions, bids must be supported by a Bid Security Declaration.
2. We accept that we will automatically be suspended from being eligible for bidding in any contract with the Institute for the period of **3 years** starting from the bid closing date, if we are in breach of our obligation(s) under the bid conditions, because we;
 - (a) have withdrawn our bid during the period of bid validity specified in the letter of bid; or
 - (b) having been notified of the acceptance of our bid by the Institute during the period of bid validity, (i) fail or refuse to execute the contract, if required, or (ii) fail or refuse to furnish the performance security, in accordance with the tender conditions.

Date:
Place:

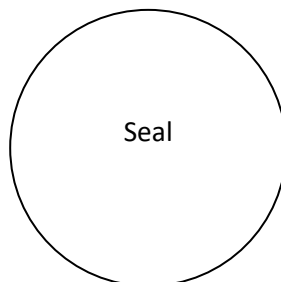

Authorized Signatory

Name:

Designation:
Contact No :

**CERTIFICATE
(To be provided on letter head of the firm)**

I hereby certify that the above firm not in active debarred list by any Central/State Government/Public Undertaking/Institute and no criminal case registered / pending against the firm or its owner / partners anywhere in India.

I also certify that the above information is true and correct in every respect and in any case at a later date it is found that any details provided above are incorrect, any contract given to the above firm may be summarily terminated and the firm may be blacklisted.

Date:

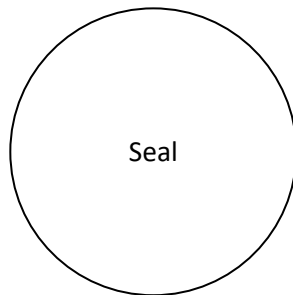

Place:

Authorized Signatory

Name:

Designation:

Contact No.:

ANNEXURE – IV

a) Experience: (As per tender Clause No.4.2 (III))

Year	Name of the Item with Specification (Technical specification brochure to be attached)	Purchase Order No. & Date (Copy of the Orders to be attached)	Date of successfully completion of SITC of ordered Item (copy of report from client to be attached)	Contact Details of Client
2016-17				
2017-18				
2018-19				
2019-20				
2020-21				

b) Past Performance: (As per tender Clause No.4.2 (III))

Sl No.	Financial Year	Quantity of similar furniture Nos	of in	Purchase Order No with No	Page	Work Completion Certificate details with Page No	Contact Address of the Client	Remarks
1.	2016-17 a) b) c)							
2	2017-18 a) b) c)							

Date :

Place :

Contact No.:

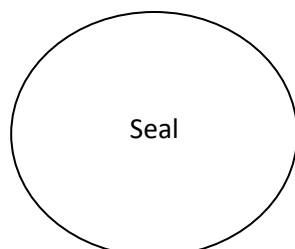

Authorized Signatory

Name:
Designation

ANNEXURE – V

Annual Turnover Details:

Evaluation Criteria			Remark	Specific page no. where the proof of documents are enclosed	
Bidder's Annual Turnover for last five financial years	Financial Year	Turnover in Rs.		-	
	2021-22			Supporting Documents are to be attached along with the Annexure-V	
	2020-21				
	2019-20				
	2018-19				
	2017-18				

Date:

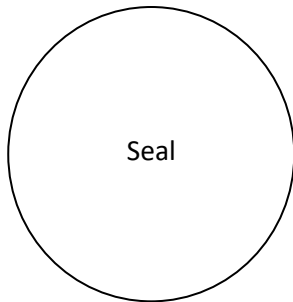

Place:

Authorized Signatory:

Name:

Designation:

Contact No.:

Format for Self-Declaration under preference to make in India order

In line with Government Public Procurement Order No. P-45021/2/2017-BE-II date. 15.06.2017 & P-45021/2/2017-PP (BE-II) dated: 04 June 2020. We hereby certify that we M/s. _____ (supplier name) are **CLASS-I/Class-II (Please specify clearly)** supplier meeting the requirement of local content more than 20% as defined in above orders for the material against Enquiry No. IITT/EU/2023-24/02 dated: 01.05.2023

Details of location at which local value addition will be made as follows: (Complete address to be mentioned)

Percentage of Local Content: _____

(As per the OM of Department of Promotion for Industry and Internal Trade No. P-45021/102/2019-BE-II-Part(1) dated: 04.03.2021. The bidders can't claim themselves as Class-I local suppliers/Class-II local suppliers by claiming the services such as transportation, insurance, installation, commissioning, training and after sales service support like AMC/CMC etc. as local value addition)

We also understand, false declarations will be in breach of the Code of Integrity under rule 175 (1) (i) (h) of the General Financial Rules for which a bidder or its successors can be debarred for up to two years as per Rule 151 (iii) of the General Financial Rules along with such other actions as may be permissible under law.

Seal and signature of Supplier

Date :

Place :

Technical Compliance statement

Description	Qty	Complied (Yes/No)	Remarks, if any	Offered Make & Model	% of Local Content as per Tender Clause No.4.2(V)	Country of Origin
Item no.1 : Granite top work benches (Standard size) (with Trunking) (with 2 LAN ports) as per the specifications of the tender clause 2.1	134 Nos					
Item no.2 : Granite top work benches (Standard size) (with Trunking) (without LAN ports) as per the specifications of the tender clause 2.2	74 Nos					
Item no.3 : Granite top work benches (high rise) (with Trunking) (without LAN ports) as per the specifications of the tender clause 2.3	171 Nos					
Item no.4 : Granite top work benches (custom size) (with Trunking) (1 LAN port) as per the specifications of the tender clause 2.4	57 Nos					
Item no.5 : Granite top work benches (custom size) (without Trunking) as per the specifications of the tender clause 2.5	34 Nos					
Item no.6 : Table with Granite Top (Special Table 1) (without trunking) as per the specifications of the tender clause 2.6	03 Nos					
Item no.7 : Table with Granite Top (Special Table 2) (without trunking) as per the specifications of the tender clause 2.7	07 Nos					
Item no.8 : Table with Granite Top (Special Table 3) (without trunking) as per the specifications of the tender clause 2.8	06 Nos					
Item no.9 : Table with Granite Top (Special Table 4) (without trunking) as per the specifications of the tender clause 2.9	04 Nos					
Item no.10 : Granite Table with sink as per the specifications of the tender clause 2.10	13 Nos					

Item no.11 : Under Bench Trolley as per the specifications of the tender clause 2.11	284 Nos					
Item no.12 : Double door Wall mounted storage cabinets as per the specifications of the tender clause 2.12	201 Nos					
Item no.13 : Student Chairs (Type 1-UG Labs) as per the specifications of the tender clause 2.13	138 Nos					
Item no.14 : Student Chairs (Type 2-Research Labs) as per the specifications of the tender clause 2.14	583 Nos					
Onsite warranty : 03 years onsite warranty for all items.						
Spares and service support availability: Minimum 05 years should be provided.						

COMPANY DETAILS

Name of the Bidder		
Date of Incorporation /		
PAN Number		
GST Registration Number		
Bidder's Bidding Capacity for the tendered items (As a Manufacturer/ Trader/ dealer / channel partner / system integrator, etc.)		
Bank Details	Account Number	
	IFS Code	
	Bank Name	
	Branch Name	
Registered Office Address		
Authorized Signatory Details (Company/Firm Authorization by the competent authority, to be attached)	Name	
	Designation	
	Email	
	Phone	
Details of Contact other than Authorized Signatory	Name	
	Designation	
	Email	
	Phone	

Date:
Tenderer:

Signature and Seal of the

Place:

Name in Block Letter:

Designation:

Contact no.

CHECKLIST FOR BIDDERS TO BE SUBMITTED IN DULY FILLED AND SIGNED

Tender Clause No.	Name of the Document	Document Particulars	Submitted (Yes/No)	Page No. of the attached Document
3.1	Tender Fee			
3.4	Bid security Declaration (Annexure-II)			
3.3	Valid Tender Fee / EMD Exemption Certificate			
4.1.	PAN Card			
	Incorporation/Registration certificate of company			
	GST Registration copy			
4.2.(I)	Tender acceptance letter (Annexure I)			
4.2.(II)	Non-Blacklisting undertaking (Annexure III)			
4.2.(III)	<p>The Bidder should submit list of clientele to whom identical or similar furniture have supplied during past five financial years i.e. during 2017-18 to 2021-22 with their contact details along with documentary evidence such as Purchase Orders executed along with technical specifications, completion certificates from the client, etc. are to be submitted as per the Annexure-IV. (On-going works will not be considered for the Technical evaluation)</p> <p>At least in any one of the calendar years (2018-2022), the number of items supplied should be more than items mentioned in tender enquiry (Pl. submit the proof of supply of identical or similar furniture).</p>			
4.2.(IV)	<p>The Annual Turnover should be at least Rs. 3.5 Crores and be profitable during each of the previous three financial years i.e. during 2018-19 to 2020-21 or 2019-20 to 2021-22. Audited financial Statements or Financial Statements showing turnover duly signed by a Chartered Accountant are to be submitted as per the Annexure-V.</p>			
4.2.(V)	<p>The Bidder should be a <u>Class-I/Class-II Local Supplier</u> meeting minimum 20% local content clause in line with the Public Procurement (Preference to Make in India) Order 2017 No. P-45021/2/2017-PP (BE-II) dated 04 Jun 2020. A Self-Declaration Certificate regarding "Class-I &</p>			

	Class-II Supplier” for the tendered items as per the Annexure-VI is to be submitted.			
4.2.(VI)	The Bidder should be OEM or OEM authorized Dealers / Channel partners / Distributors of reputed brand having authorization for sales and after sales support. Valid OEM authorization letter is required to participate in this tender.			
4.2.(VII)	Any bidder from a country which shares a land border with India will be eligible to bid in this tender only if the Bidder registered with the competent authority. The concerned Bidder (s) are required to attach the relevant valid Registration Certificate along with the bid for consideration.			
4.3	Technical Compliance Statement : Annexure-VII.			
4.2 (IX)	The Bidder should have submit below mentioned certificates <ol style="list-style-type: none"> 1. SEFA-3 and SEFA-8 2. BIFA X 5.5 2021 for office and Institutional furnishing 3. ISO 9001:2015 for the firm 4. All the component shall confirm to the relevant IS standards specifications 			
11.1 (I)	Purchase Preference: (if applicable) Micro and Small Enterprises (MSEs):			
11.2 (II)	Purchase Preference: Make in India			
12	Payment Term: Within 30 days after SITC.			
13.	Onsite Warranty: 03 Years onsite warranty for all the items			
15	Delivery: within 12 weeks (84 days) from the date of sample approved by the committee at the factory.			
8	Bid validity: 120 days from the date of opening of the tender			
	Company details : Annexure-VIII			

Note: Submission of tender without the documents mentioned above will lead to rejection/disqualification of the tender.

Signature of the Bidder with stamp

ANNEXURE-X

Format for submitting the queries through email to IIT Tirupati

QUERIES RELATED TO THE TENDER DOCUMENT MAY BE FORWARDED TO eutenders@iittp.ac.in AS PER THE BELOW FORMAT OF ANNEXURE-X

Tender No. IITT/EU/2023-24/02 dated: 01.05.2023

Name of the Tender/Supply: Notice Inviting Tender for Supply, installation, testing and Commissioning of Computer Lab Furniture.

S No	Tender Clause No	Bidder(s) queries	IIT Tirupati response

Signature and Seal of the Tenderer:

Name in Block Letter:

Designation:

Full Address:

Contact no.:

Date:

INTEGRITY PACT

To,
The Registrar,
Indian Institute of Technology,
Tirupati.

Sub: Submission of Tender for the _____ at
Indian Institute of Technology, Tirupati.

Sir/ Madam,

I/We acknowledge that the Indian Institute of Technology, Tirupati is committed to follow the principles thereof as enumerated in the Integrity Agreement enclosed with the tender/bid document.

I/We agree that the Notice Inviting Tender (NIT) is an invitation to offer made on the condition that I/We will sign the enclosed integrity Agreement, which is an integral part of tender documents, failing which I/We will stand disqualified from the tendering process. I/We acknowledge that THE MAKING OF THE BID SHALL BE REGARDED AS AN UNCONDITIONAL AND ABSOLUTE ACCEPTANCE of this condition of the NIT.

I/We confirm acceptance and compliance with the Integrity Agreement in letter and spirit and further agree that execution of the said Integrity Agreement shall be separate and distinct from the main contract, which will come into existence when tender/bid is finally accepted by Indian Institute of Technology, Tirupati. I/We acknowledge and accept the duration of the Integrity Agreement, which shall be in the line with Article 1 of the enclosed Integrity Agreement.

I/We acknowledge that in the event of my/our failure to sign and accept the Integrity Agreement, while submitting the tender/bid, Indian Institute of Technology, Tirupati shall have unqualified, absolute and unfettered right to disqualify the tenderer/bidder and reject the tender/bid in accordance with terms and conditions of the tender/ bid.

Yours faithfully,

(Duly authorized signatory of the Bidder)

INTEGRITY PACT

This **INTEGRITY PACT** is made and executed at..... on this day of..... , 2022

BETWEEN

The Registrar, Indian Institute of Technology Tirupati, an autonomous body of the Department of Higher Education, Ministry of Education, Govt, of India having its office located at Yerpedu – Venkatagiri Road, Yerpedu Post, Tirupati District, Andhra Pradesh - 517619 (hereinafter referred to as “**The Principal**” which terms or expression shall, unless excluded by or repugnant to the subject or context, mean and include its successor-in-office, administrators or permitted assignees) of the **First Part**;

And

M/s..... a company incorporated under the Companies Act,..... through its representative/authorized signatory (insert name and designation of the officer) vide resolution dated passed by the Board of Directors, having its office at(hereinafter referred to as “**The Bidder/Contractor**” which term or expression shall, unless excluded by or repugnant to the subject or context, mean and include its successor-in-office, administrators or permitted assignees) of the **Second Part**.

Preamble

The Principal intends to award, underlaid down organizational procedures, contract/s for _____ The Principal values full compliance with all relevant laws of the land, rules, regulations, economic use of resources and of fairness / transparency in its relations with its Bidders) and / or Contractor(s).

In order to achieve these goals, the Principal will appoint Independent External Monitors (IEMs) who will monitor the tender process and the execution of the contract for compliance with the principles mentioned above.

Section 1 - Commitments of the Principal

(1) The Principal commits itself to take all measures necessary to prevent corruption and to observe the following principles:-

- a. No employee of the Principal, personally or through family members, will in connection with the tender for, or the execution of a contract, demand, take a promise for or accept, for self or third person, any material or immaterial benefit which the person is not legally entitled to.
- b. The Principal will, during the tender process treat all Bidder(s) with equity and reason. The Principal will in particular, before and during the tender process, provide to all Bidder(s) the same information and will not provide to any Bidder(s) confidential/additional information through which the Bidder(s) could obtain an advantage in relation to the tender process or the contract execution.
- c. The Principal will exclude from the process all known prejudiced persons.

(2) If the Principal obtains information on the conduct of any of its employees which is a criminal offence under the IPC/PC Act, or if there is a substantive suspicion in this regard, the Principal will inform the Chief Vigilance Officer and in addition, can initiate disciplinary actions.

Section 2 - Commitments of the Bidder(s)/ Contractor(s)

(1) The Bidder(s)/ Contractor(s) commit themselves to take all measures necessary to prevent corruption. The Bidder(s)/ Contractor(s) commit themselves to observe the following principles during participation in the tender process and during the contract execution.

a. The Bidder(s)/ Contractor(s) will not, directly or through any other person or firm, offer, promise or give to any of the Principal's employees involved in the tender process or the execution of the contract or to any third person any material or other benefit which he/she is not legally entitled to, in order to obtain in exchange any advantage of any kind whatsoever during the tender process or during the execution of the contract.

b. The Bidders(s)/ Contractor(s) will not enter with other Bidders into any undisclosed agreement or understanding, whether formal or informal. This applies in particular to prices, specifications, certifications, subsidiary contracts, submission or non-submission of bids or any other actions to restrict competitiveness or to introduce cartelization in the bidding process.

c. The Bidder(s)/ Contractor(s) will not commit any offense under the relevant IPC/PC Act; further the Bidders(s)/ Contractor(s) will not use improperly, for purposes of competition or personal gain, or pass on to others, any information or document provided by the Principal as part of the business relationship, regarding plans, technical proposals and business details, including information contained or transmitted electronically.

d. The Bidder(s)/ Contractors(s) of foreign origin shall disclose the name and address of the Agents/representatives in India, if any. Similarly, the Bidder(s)/Contractors(s) of Indian Nationality shall furnish the name and address of the foreign principals, if any. Further details as mentioned in the "Guidelines on Indian Agents of Foreign Suppliers" shall be disclosed by the Bidder(s)/Contractor(s). Further, as mentioned in the Guidelines all the payments made to the Indian agent/representative have to be in Indian Rupees only

e. The Bidder(s)/ Contractor(s) will, when presenting their bid, disclose any and all payments made, is committed to or intends to make to agents, brokers or any other intermediaries in connection with the award of the contract.

f. Bidder(s) /Contractor(s) who have signed the Integrity Pact shall not approach the Courts while representing the matter to IEMs and shall wait for their decision in the matter.

(2) The Bidders)/ Contractors) will not instigate third persons to commit offences outlined above or be an accessory to such offences.

Section 3 - Disqualification from tender process and exclusion from future contracts

If the Bidder(s)/Contractor(s), before award or during execution has committed a transgression through a violation of Section 2, above or in any other form such as to put their reliability or credibility in question, the Principal is entitled to disqualify the Bidder(s)/Contractor(s) from the tender process or take action as per the procedure mentioned in the "Guidelines on Banning of business dealings.

Section 4 - Compensation for Damages

(1) If the Principal has disqualified the Bidder(s) from the tender process prior to the award according to Section 3, the Principal is entitled to demand and recover the damages equivalent to Earnest Money Deposit/Bid Security.

(2) If the Principal has terminated the contract according to Section 3, or if the Principal is entitled to terminate the contract according to Section 3, the Principal shall be entitled to demand and recover from the Contractor liquidated damages of the Contract value or the amount equivalent to Performance Bank Guarantee.

Section 5 - Previous transgression

(1) The Bidder declares that no previous transgressions occurred in the last three years with any other Company in any country conforming to the anti-corruption approach or with any Public Sector Enterprise in India that could justify his exclusion from the tender process.

(2) If the Bidder makes incorrect statement on this subject, he can be disqualified from the tender process or action can be taken as per the procedure mentioned in "Guidelines on Banning of business dealings".

Section 6 - Equal treatment of all Bidders / Contractors / Subcontractors

(1) In the case of Sub-contracting, the Principal Contractor shall take the responsibility for the adoption of the Integrity Pact by the Sub-contractor.

(2) The Principal will enter into agreements with identical conditions as this one with all Bidders and Contractors.

(3) The Principal will disqualify from the tender process all bidders who do not sign this Pact or violate this provisions.

Section 7 - Criminal charges against violating Bidder(s) / Contractors) / Subcontractor(s)

If the Principal obtains knowledge of conduct of a Bidder, Contractor or Subcontractor, or of an employee or a representative or an associate of a Bidder, Contractor or Subcontractor which constitutes corruption, or if the Principal has substantive suspicion in this regard, the Principal will inform the same to the Chief Vigilance Officer.

Section 8 - Independent External Monitor

(1) The Principal appoints a competent and credible Independent External Monitor for this Pact after approval by Central Vigilance Commission. The task of the Monitor is to review independently and objectively, whether and to what extent the parties comply with the obligations under this agreement.

(2) The Monitor is not subject to instructions by the representatives of the parties and performs his/her functions neutrally and independently. The Monitor would have access to all Contract documents, whenever required. It will be obligatory for him/her to treat the information and documents of the Bidders/Contractors as confidential. He/she reports to Secretary, MoE.

(3) The Bidder(s)/Contractor(s) accepts that the Monitor has the right to access without restriction to all Project documentation of the Principal including that provided by the Contractor. The Contractor will also grant the Monitor, upon his/her request and demonstration of a valid interest,

unrestricted and unconditional access to their project documentation. The same is applicable to Sub-contractors.

(4) The Monitor is under contractual obligation to treat the information and documents of the Bidders)/ Contractor(s)/ Sub-contractor(s) with confidentiality. The Monitor has also signed declarations on 'Non-Disclosure of Confidential Information and of 'Absence of Conflict of Interest'. In case of any conflict of interest arising at a later date, the IEM shall inform Secretary, D/o Higher Education.

(5) The Principal will provide to the Monitor sufficient information about all meetings among the parties related to the Project provided such meetings could have an impact on the contractual relations between the Principal and the Contractor. The parties offer to the Monitor the option to participate in such meetings.

(6) As soon as the Monitor notices, or believes to notice, a violation of this agreement, he/she will so inform the Management of the Principal and request the Management to discontinue or take corrective action, or to take other relevant action. The monitor can in this regard submit non-binding recommendations. Beyond this, the Monitor has no right to demand from the parties that they act in a specific manner, refrain from action or tolerate action.

(7) The Monitor will submit a written report to the Secretary, D/o Higher Education within 8 to 10 weeks from the date of reference or intimation to him by the Principal and, should the occasion arise, submit proposals for correcting problematic situations.

(8) If the Monitor has reported to the Secretary, D/o Higher Education, a substantiated suspicion of an offence under relevant I PC/ PC Act, and the Secretary, MoE has not, within the reasonable time taken visible action to proceed against such offence or reported it to the Chief Vigilance Officer, the Monitor may also transmit this information directly to the Central Vigilance Commissioner.

(9) The word '**Monitor**' would include both singular and plural.

Section 9 - Pact Duration

This Pact begins when both parties have legally signed it. It expires for the Contractor 12 months after the last payment under the contract, and for all other Bidders 6 months after the contract has been awarded. Any violation of the same would entail disqualification of the bidders and exclusion from future business dealing.

If any claim is made / lodged during this time, the same shall be binding and continue to be valid despite the lapse of this pact as specified above, unless it is discharged / determined by Secretary, D/o Higher Education.

Section 10 - Other provisions

(1) This agreement is subject to Indian Law. The place of performance and jurisdiction is the Office of the Principal, i.e. New Delhi.

(2) Changes and supplements as well as termination notices need to be made in writing. Side agreements have not been made.

(3) If the Contractor is a partnership or a consortium, this agreement must be signed by all partners or consortium members.

(4) Should one or several provisions of this Pact turn out to be invalid, the remainder of this Pact remains valid. In this case, the parties will strive to come to an agreement with their original intentions.

(5) Issues like Warranty / Guarantee etc. shall be outside the purview of IEMs.

(6) In the event of any contradiction between the Integrity Pact and its Annexure, the Clause in the Integrity Pact will prevail.

(7) The actions stipulated in this Integrity Pact are without prejudice to any other legal action(s) that may follow in accordance with the provisions of the extant law in force relating to any civil or criminal proceedings.

IN WITNESS WHEREOF, the parties hereunto set their hands and seals and executed this INTEGRITY PACT as of the day/month/year first above written:

For and on behalf of

**THE REGISTRAR,
Indian Institute Technology Tirupati (First Party)**

SIGNED, SEALED, AND DELIVERED by

Name:.....

Designation:.....

Address:.....

Authorized Signatory

For and on behalf of

M/s.....(Second Party)

SIGNED, SEALED AND DELIVERED by

Name _____

Designation:.....

Address:.....

Representative/authorized signatory

Vide resolution dated..... passed by the Board of Directors

In the presence of Witness:

1.

2.